

"CLEAR VIEW"

Into

Vacuum Systems Operation & Testing

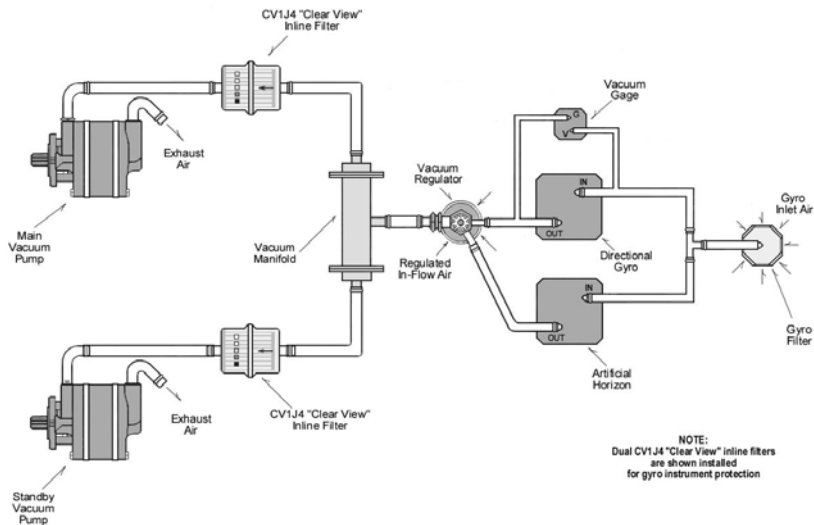

Introduction

The aircraft pneumatic system is one of the most maintenance neglected systems on the single engine aircraft.

The majority of pilots and mechanics are under the misconception the vacuum gage, located on the instrument panel, indicates "system" and/or air pump vacuum. It is not until the pilot experiences a pump failure in flight, than an attempt is made to understand the basic operation of the system. In many cases the failed air pump is changed, the filters may be exchanged for new ones, but no further effort is made to determine the original cause of failure.

The statement "**Air pumps just fail unexpectedly and for no reason**" is usually expelled from the mouths of lawyers, not well-trained mechanics or knowledgeable pilots.

In more cases than not, a system problem causing undue pressure on the air pump is the real reason for sudden failure. Unfortunately, it isn't until several pumps are changed that a serious attempt is made to investigate the true cause of failure.

Motivated by the cost of continued pump replacement, the owner is usually hindered in eliminating his pump failures by the overall lack of knowledge by the majority of mechanics in the field.

* This is not to say that the licensed aircraft mechanic is inept or uneducated, however, with the need for training in fuel and ignitions systems, propellers, brakes, engine and structures, little time is available for the "simple" air pump system and it's components.

REMEMBER!

Replacing an air pump and running the aircraft engine to confirm proper operation does no more than confirm the indicating needle in the vacuum gage is still attached to it's shaft.

Our Goal

To provide a "**Clear View**" into the proper operation and testing of single engine aircraft vacuum gyro instrument systems.

A "CLEAR VIEW"

Into Vacuum Systems Operation & Testing

Misconception

The vacuum gage located on the aircraft instrument panel indicates gyro system vacuum or air pump vacuum.

Fact

With airflow through the gyro instruments for operation, a pressure drop is developed between the inlet and outlet port of that instrument. Since the gyro instrument vacuum gage (refer below) is connected in parallel (across) one of the gyro instruments, this pressure drop is indicated on the panel vacuum gage.

Aircraft gyro instruments and systems have been designed to operate properly when the airflow through the gyro instrument creates a pressure drop of 4.7" Hg. to 5.2" Hg. as usually green lined on the panel vacuum gage.

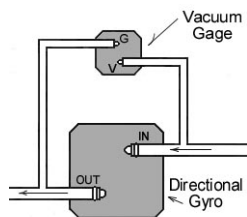

Engine Log Book Entry

"Changed Pump" "Run Engine, Checks OK"

How many times have you seen that logbook entry?

Based on what was discussed in the previous paragraphs, running the engine after a new pump installation will not confirm proper pump or system operation, but rather the amount of airflow through the gyro instruments. If a system contains leaking hoses or loose fittings, the 2H3 vacuum regulator may have been adjusted to compensate for this leakage, requiring the air pump to produce more vacuum than normal.

Pump Vacuum = Pump Life

In a proper operating pneumatic system, pump vacuum is 1.5" Hg. higher than the gyro vacuum gage reading.

With a typical gage reading of 5" Hg. air pump vacuum is 6-1/2" Hg. (3-1/4 psi). Life expectancy should be 800 to 900 hours.

1" Hg. = 1/2 psi
1.5" Hg. = 3/4 psi
5" Hg. = 2-1/2 psi

Double or triple the pump vacuum to 12-20" Hg. and start replacing air pumps every 200 – 300 hours!

Proper System Testing

Short pump life is habitually the result of one or more discrepancies in the vacuum system that has not been detected during routine maintenance checks or annual inspections.

By conducting a complete check of the entire pneumatic system all defects that may cause short pump life can be identified and eliminated.

To obtain accurate results without the noise of an operating engine and the hazards of a spinning prop, the following paragraphs outline test procedures using "ordinary shop air" and the Aerotech CV-700 Pneumatic Test Kit.

The CV-700 Pneumatic Test Kit will provide the proper tools to aid in the evaluation of each system component through complete pneumatic system testing. A step-by-step guide is supplied for easy and accurate measurements with "Test Results" pages for continuous record keeping.



Pressure regulator (CV-R400) is supplied with a 0-100 psi gage. The sliding air shut-off connection provided at the inlet is suitable for shop air attachment along with a quick connect fitting at the outlet for ejector (CV-I480) attachment

The CV-I480 ejector assembly creates the vacuum for system testing. A 5/8 in. O.D. hose fitting allows for system connection. The 0-30" Hg. gage indicates vacuum being applied to the aircraft' system.



Vacuum measurements at various locations in the system are taken with a gage assembly, (CV-G30) consisting of a combination 30-0-30 vacuum/pressure gage connected to a "probe" via clear plastic tubing. The 18 gage "deflecting tip needle" will not damage pneumatic rubber hose.

AEROTECH COMPONENTS, INC.

Page 2

A "CLEAR VIEW"

Into Vacuum Systems Operation & Testing

General

It is not our intent to outline complete trouble-shooting procedures for all types of aircraft and all pneumatic systems, but rather provide a simple outline of test procedures for single engine aircraft, which may or may not be operating a standby air pump.

While Fig 1. is a general representation of most single engine vacuum gyro instrument systems, you may encounter a different configuration on your aircraft.

Consult the aircraft manufacturer's system diagrams for component location and test points. Aerotech CV1J4 "Clear View" filters are shown installed for gyro instrument protection.

BE ALERT!

These test procedures call for the insertion of the test gage probe into the system hose at certain points for vacuum measurements. Some aircraft systems have been assembled using poly-flow, surgical, or clear plastic tubing. Do Not use the test gage probe on this type hose. Any holes created by the probe will not reseal and will create a permanent leak in the system

Test Procedures

1. Remove aircraft system hose from air pump at test point **A**.
2. Connect the CV-R400 test regulator and CV-I480 ejector combination to the aircraft system (Test Point **A**) via 5/8 O.D. fitting on the ejector.
 - a. The regulator adjustment knob should be counter clockwise (no pressure applied). The "On-Off" slide valve should be in the "Off" position (toward the shop air source).
3. Connect the shop air source to the inlet of the test CV-R400 Regulator.
4. Slide the "On-Off" valve to the "On" position and slowly turn the regulator adjustment knob clockwise applying pressure to the CV-I480 test ejector.
 - a. As you monitor the aircraft gyro vacuum gage, it will slowly rise to a maximum point and stop at the value preset by the aircraft 2H3 vacuum regulator.
5. Turn the CV-R400 regulator adjustment knob two more complete turns. This will apply more vacuum to the aircraft system forcing the 2H3 vacuum regulator to open, allowing ambient air into the system.
6. Record the vacuum indicated on the CV-I480 test ejector gage.

NOTE:
This is the vacuum the air pump has to develop at all times, to maintain the value indicated on your gyro instrument vacuum gage.
7. Subtract the reading of the instrument panel vacuum gage from the reading indicated on the test ejector gage.
 - a. The difference should be 1.5" Hg. or less.
8. A large value recorded on the ejector gage will indicate loose hose clamps, loose or deteriorated hose, restricted gyro inlet filter, or even a defective gyro instrument vacuum gage.

Remember!
Any value greater than the 1.5" Hg. difference will shorten the life of your air pump.
9. If provided with a standby air pump, each side of the system should be tested separately.
 - a. When testing the "main pump side", confirm that air is not allowed into the system from the "standby side" through a faulty check valve located in the vacuum manifold.
 1. Disconnect the "standby side" vacuum hose from the manifold and seal the manifold fitting. (Refer to test point **D**).
10. If equipped with a manual selector valve (Main/Standby), test in both positions for proper operation.
11. To confirm gyro vacuum gage accuracy, insert the test probe into the instrument line at test point **B**.

"A "CLEAR VIEW"

Into Vacuum Systems Operation & Testing

Test Procedures (con't)

11. When the test probe is inserted at test point **C**, the reading should be zero if the gyro inlet filter is clean and unobstructed.
12. After all defects have been corrected and the gyro instrument vacuum gage reflects the correct manufacturer's recommended setting, disconnect all test equipment and reinstall the vacuum line to the air pump.
13. Run the aircraft engine to re-confirm proper pump/system operation.
14. Complete the paper work!
7. If, during your annual inspection, the pneumatic system was checked by merely running the engine,
YOU HAVE A MECHANIC PROBLEM !!
8. If you think your mechanic may be incompetent in maintaining your pneumatic system, please refer back to the second column, second paragraph of page 1, noted by the (*).

Points to Ponder

1. If the new air pump you just installed did not last at least 900 hours,
YOU HAVE A SYSTEM PROBLEM !
2. If the previous pump you installed lasted longer than the one you just replaced,
YOU HAVE A SYSTEM PROBLEM !
3. If you had to re-adjust your 2H3 regulator to obtain a correct gyro vacuum gage reading,
YOU HAVE A SYSTEM PROBLEM !
4. If your gyro vacuum gage remains below the green arc (4.7"- 5.2" Hg) until you reach high engine rpm,
YOU HAVE A SYSTEM PROBLEM !
5. If your vacuum gage reads lower at altitude than it does taxiing around the airport,
YOU HAVE A SYSTEM PROBLEM !
6. If you contacted your FBO or aircraft mechanic concerning any of the problems indicated above and he recommended you bring the aircraft in for a "regulator adjustment",
YOU HAVE A MECHANIC PROBLEM !!

WE ALL HAVE A PROBLEM...

KEEPING UP WITH THE
LATEST INFORMATION
AVAILABLE TO US ON A
DAILY BASIS.

DO YOURSELF AND US A FAVOR!

**PASS THIS INFORMATION ON TO
OTHERS THAT MAY BE HAVING
PNEUMATIC SYSTEM PROBLEMS,**

THEN CONTACT:

AEROTECH COMPONENTS, INC.

**For Technical Expertise
In Pneumatic System Maintenance**



CV1J4

**The Only Filter Guaranteed
For the Life of the Air Pump**

AEROTECH COMPONENTS, INC.

Page 4

A "CLEAR VIEW"

Into Vacuum Systems Operation & Testing

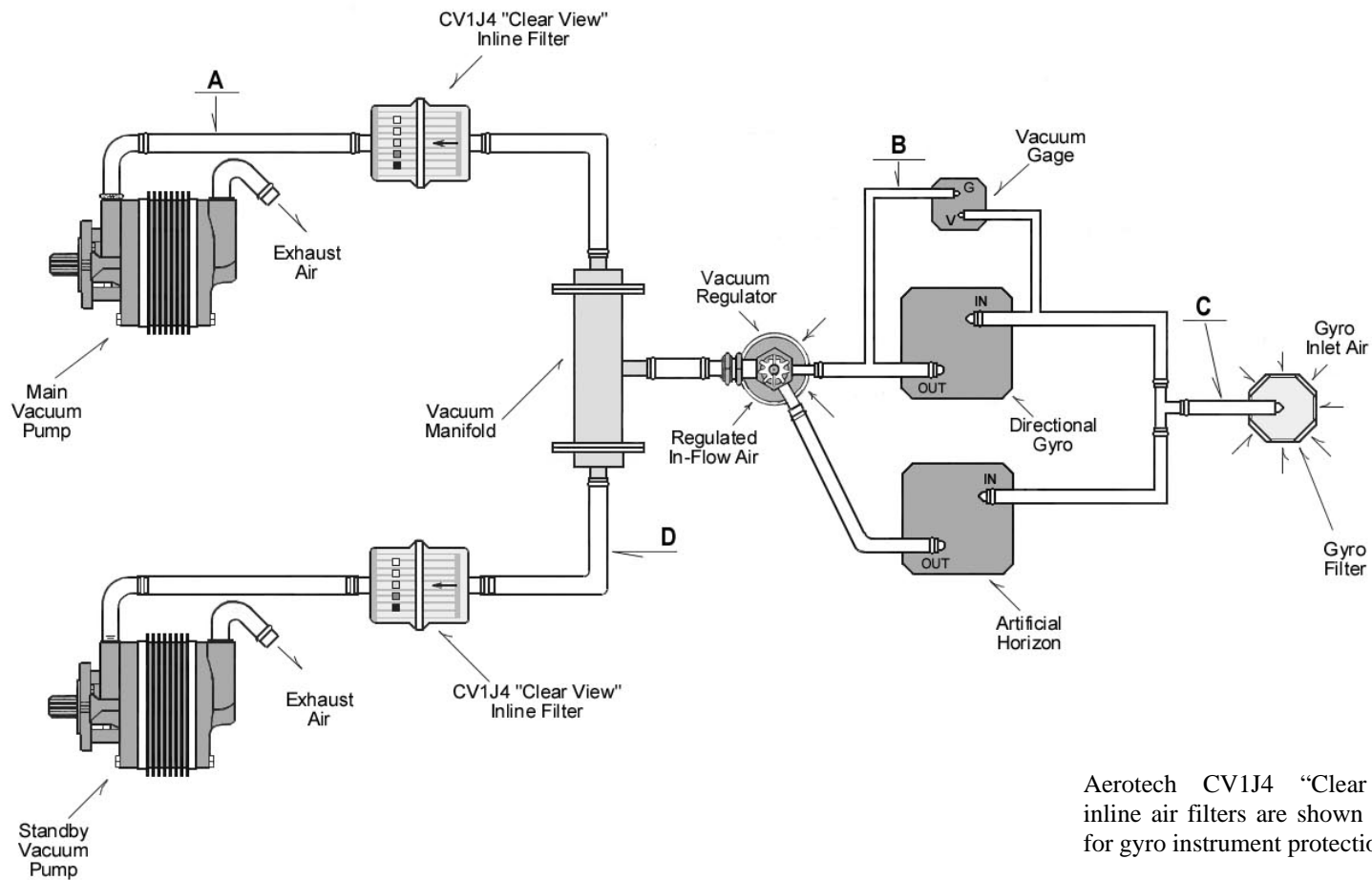

Aerotech CV1J4 "Clear View" inline air filters are shown installed for gyro instrument protection.

Fig. 1